



# NGL SHIPPING ENERGY OPTIMIZATION

By  
**ALSADAT ALGHAMDI**  
BERRI GAS PLANT  
ENGINEERING DIVISION

November 30, 2011



# Outlines



**Objectives**

**NGL Shipping Process Overview**

**Inherent System Drawbacks**

**Proposed Solutions**

**Required Modifications**

**Financial Analysis**

**Comparison of Current & New Changes**

**Summary**

# Objectives

- Eliminating inherent system drawbacks associated with the existing NGL shipping process
- Enhancing reliability
- Reducing energy loss
- Accruing financial gains



# Outlines

Objectives

**NGL Shipping Process Overview**

Inherent System Drawbacks

Proposed Solutions

Required Modifications

Financial Analysis

Comparison of Current & New Changes

Summary

# Existing NGL Shipping Process

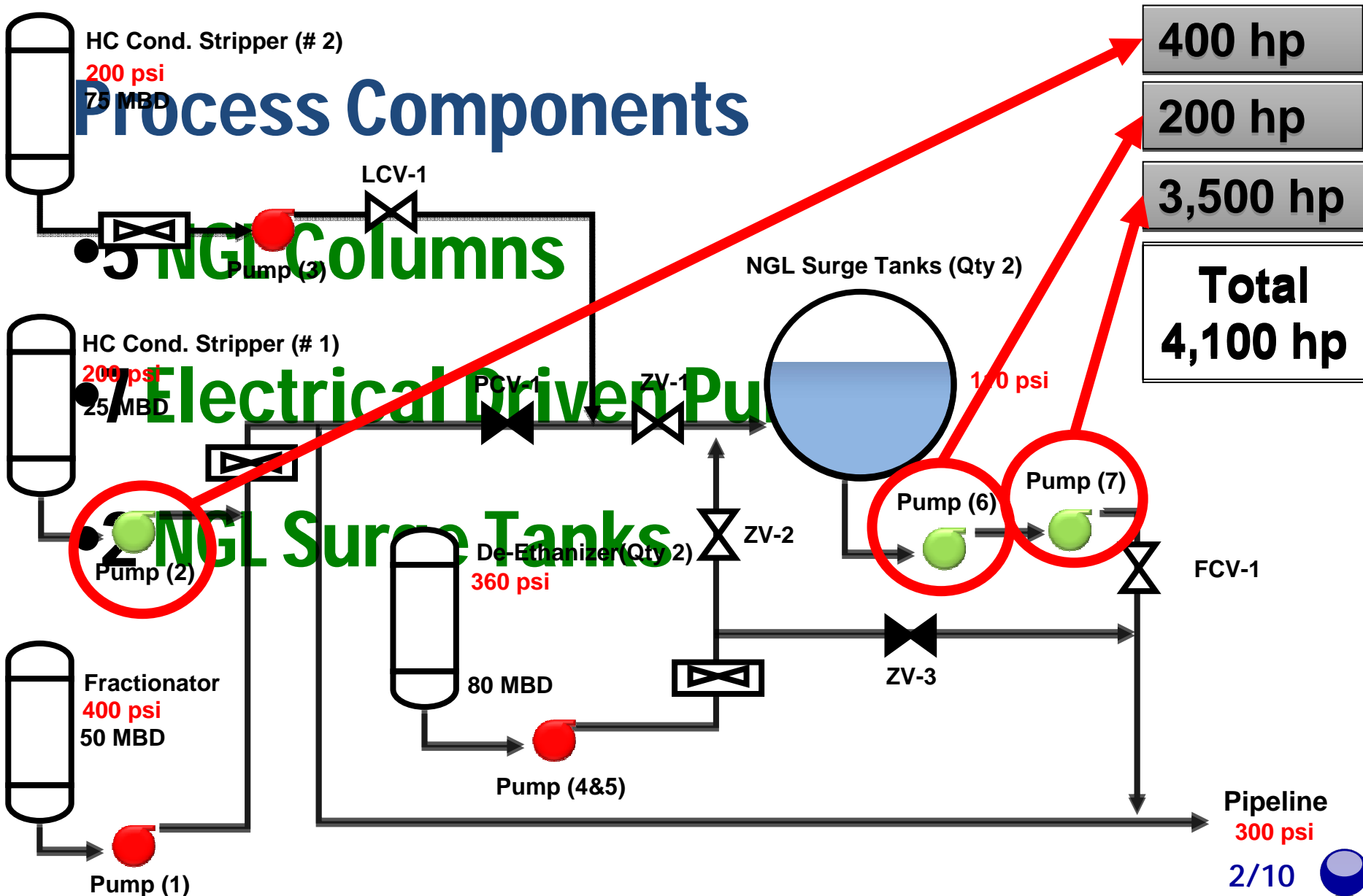

# Outlines

Objectives

NGL Shipping Process Overview

**Inherent System Drawbacks**

Proposed Solutions

Required Modifications

Financial Analysis

Comparison of Current & New Changes

Summary

# Inherent System Drawbacks

- Vibration & Noise on LCV-1; High Diff. (P) 
- Noise at Shipping Pump Area (Pump 7)
- Possibility of Pipeline pressure exceeding the max. allowable pressure of 450 psi  
*(Pump 7 max. discharge pressure is 1000 psi)*
- Wasting (2,628 hp)1.93 MW



# Outlines

Objectives

NGL Shipping Process Overview

Inherent System Drawbacks

**Proposed Solutions**

Required Modifications

Financial Analysis

Comparison of Current & New Changes

Summary



# Proposed Solutions

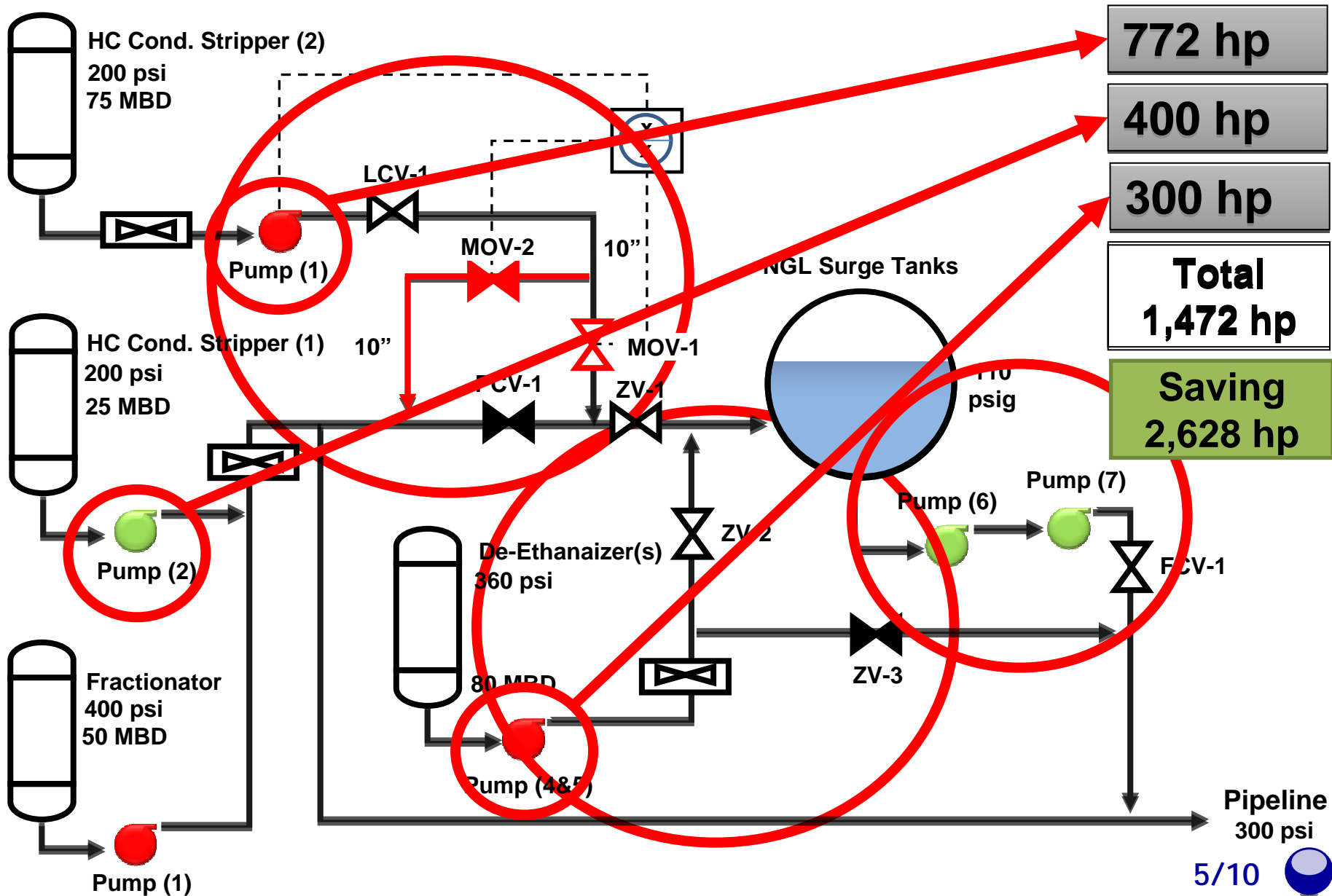

# Outlines

Objectives

NGL Shipping Process Overview

Inherent System Drawbacks

Proposed Solutions

**Required Modifications**

Financial Analysis

Comparison of Current & New Changes

Summary

# Required Modifications (1)

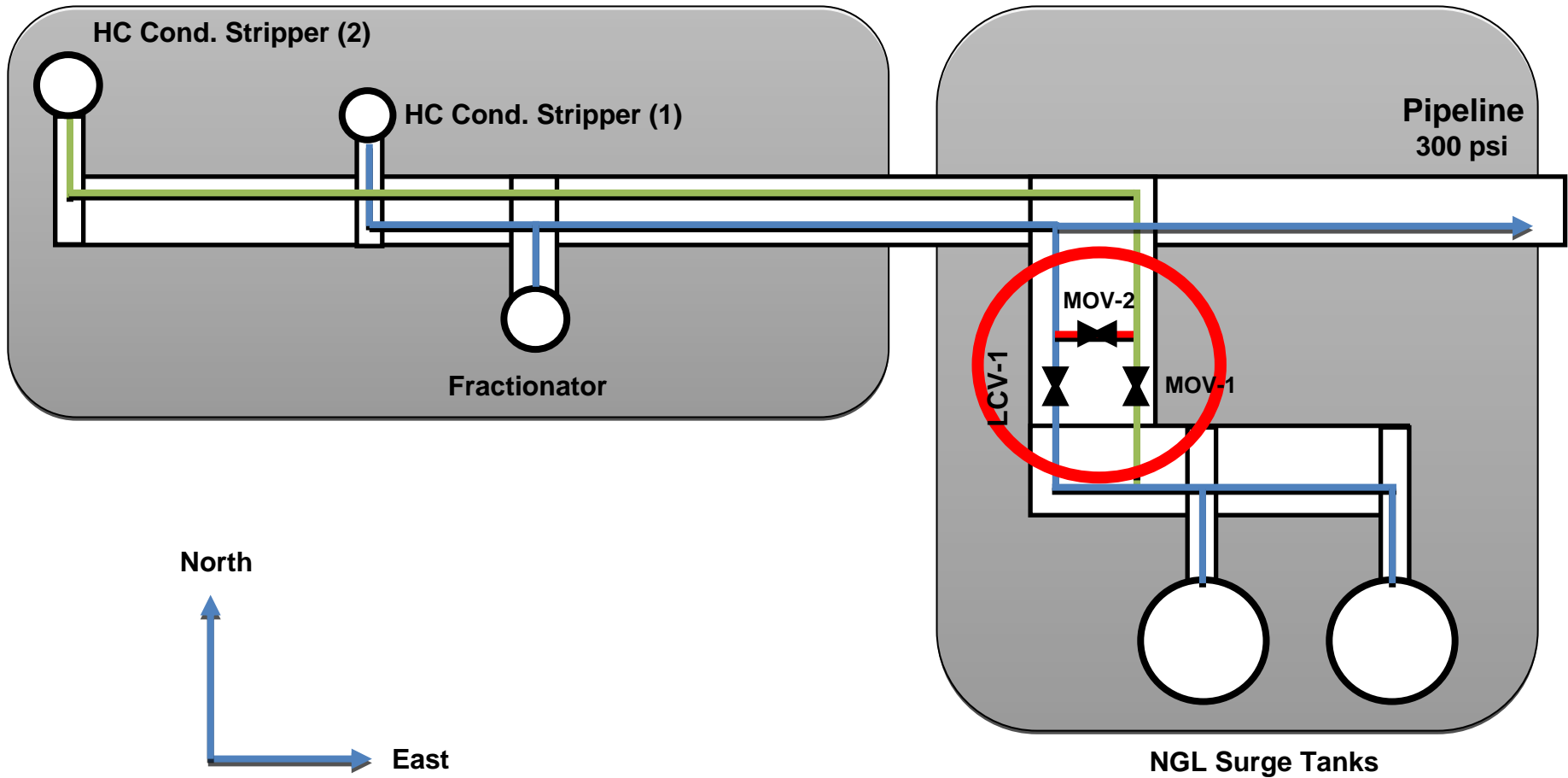

# Required Modifications (2)

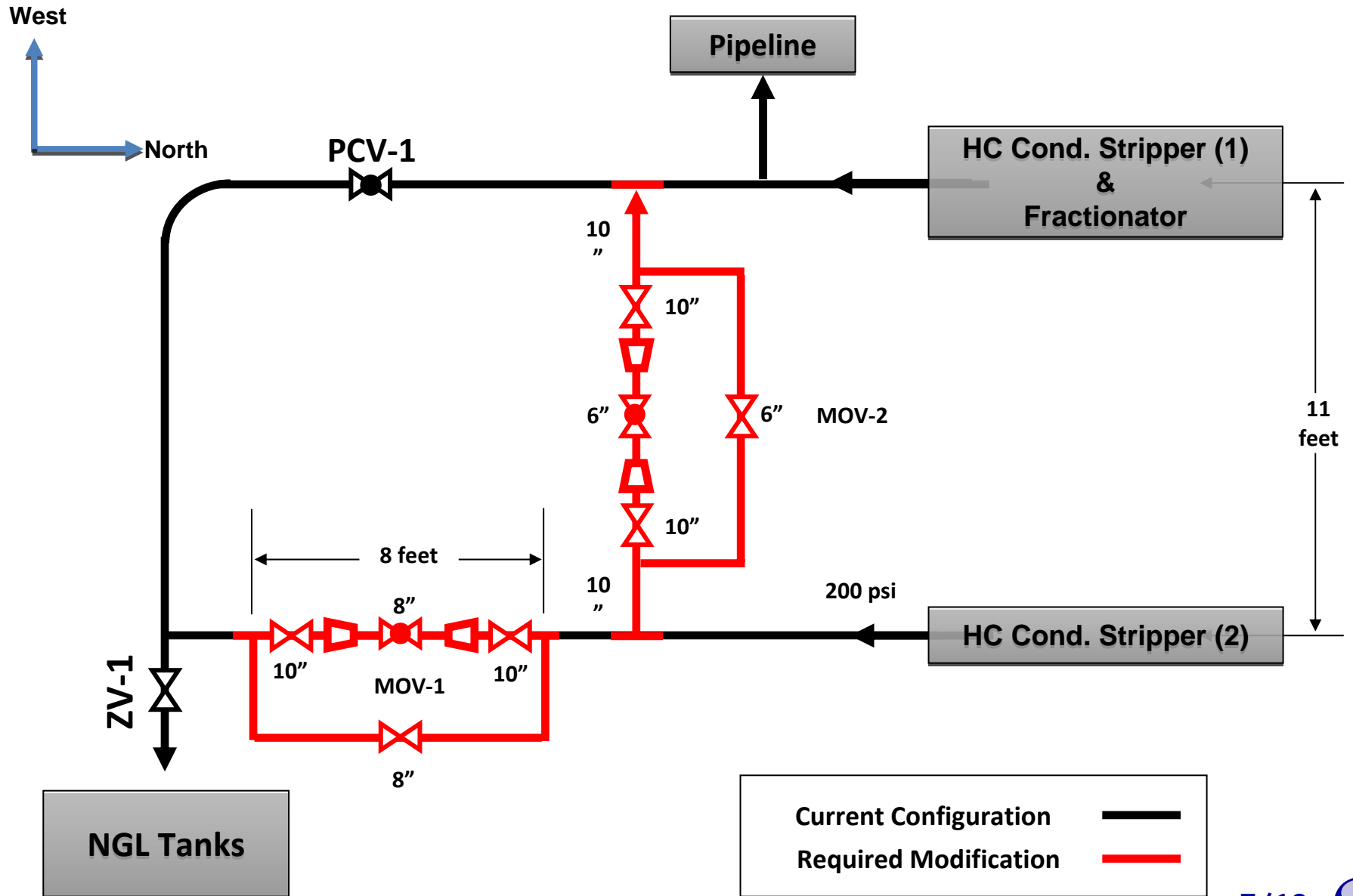

# Outlines

Objectives

NGL Shipping Process Overview

Inherent System Drawbacks

Proposed Solutions

Required Modifications

**Financial Analysis**

Comparison of Current & New Changes

Summary

# Financial Analysis

$$\frac{\text{Modification Cost (\$)}}{\text{Revenue (\$)}} = 17\%$$

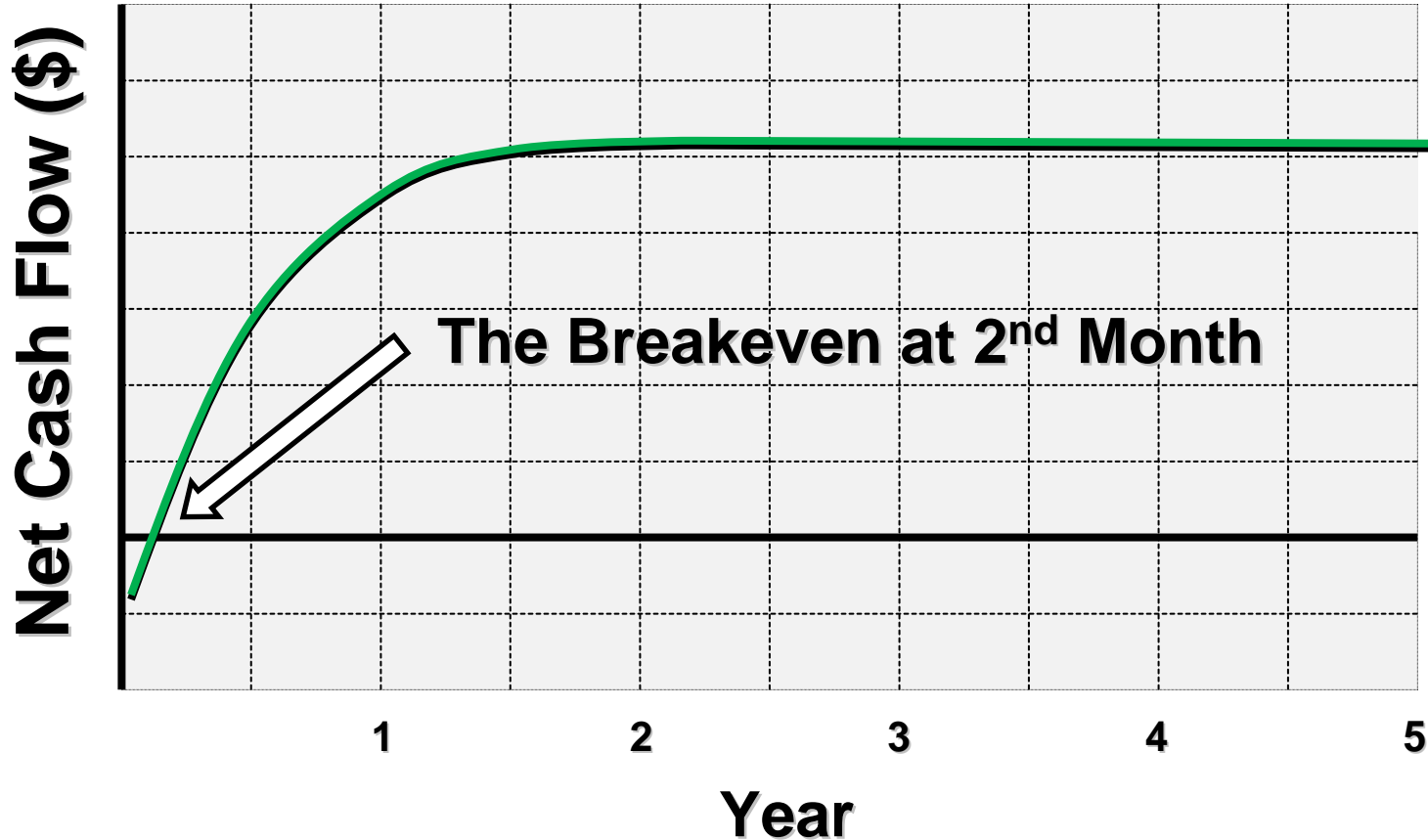

# Outlines

Objectives

NGL Shipping Process Overview

Inherent System Drawbacks

Proposed Solutions

Required Modifications

Financial Analysis

**Comparison of Current & New Changes**

Summary

# Comparison of Current & New Changes

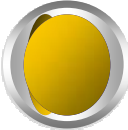
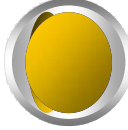
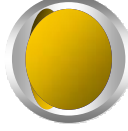
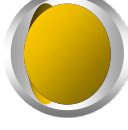
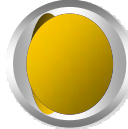
	DESCRIPTION	EXIST	NEW
	Vibration & Noise on LCV-1	Yes	No
	Keeping Pipeline Pressure < 450 psi	No	Yes
	Energy Saving (Revenue)	No	Yes
	Required Modifications	No	Yes
	Pump (6/7) Life-Time Increment	No	Yes





# Outlines

Objectives

NGL Shipping Process Overview

Inherent System Drawbacks

Proposed Solutions

Required Modifications

Financial Analysis

Comparison of Current & New Changes

**Summary**











# Summary

- Vibration & Noise on LCV-1 were the trigger factors of this initiative.
- System inherited these problems due to the expansion of the NGL producer and overlooking existing system sizing and hydrolysis.
- This proposal will eliminate the vibration, noise and save \$.
- Reliability of NGL shipping pump will be improved.



# Questions



- 1/10 
- 2/10 
- 3/10 
- 4/10 
- 5/10 
- 6/10 
- 7/10 
- 8/10 
- 9/10 
- 10/10 

ALSADAT AL-GHAMDI

Email: [ghamsh0t@aramco.com](mailto:ghamsh0t@aramco.com)

Nov 30, 2011

# LCV-1 (High Differential Pressure)

